

Exhibit "A"



Cross-Connection Control Manual

Revised Date: March 2026
Reviewed Date: March 2026
Board Approval Date: April 2026

Preface

This manual including Appendices A and B is a manual of policies and specifications for a Cross-Connection Control program adopted by the Board of Supervisors of Tohopekaliga Water Authority.

This manual of policies and specifications is adopted by TOHO Resolution No. 2018-003 and serves as a guide to ensure that safe potable water is maintained.

Tohopekaliga Water Authority:

1. Urges the reading of this manual of policies and specifications before designing or installing a backflow prevention device assembly to ensure the safety of drinking water.
2. Believes the material in this manual will provide the consumer with an understanding of cross-connections and backflow assemblies.
3. Will ensure that the policies, standards and specifications as set forth in this manual will be uniformly administered and enforced.

If there are any questions regarding this manual or policies, please call TOHO at (407)944-5000 and ask for the Cross-Connection Program.

Revised Date: March 2026
Reviewed Date: March 2026
Board Approval Date: April 2026

Introduction

Tohopekaliga Water Authority (TOHO) has had a Cross-Connection Control program for many years. The purpose of the program is to protect the potable water supply from contamination resulting from backpressure and backsiphonage, as those terms are defined herein. This Manual is intended to supersede and replace the Cross-Connection Control Plan adopted by the TOHO Board of Supervisors in 2011. This program applies to both residential and commercial customers. TOHO's Cross-Connection Control program adheres to the following requirements established by state regulation (Rule 62-555.360, Florida Administrative Code (F.A.C.)):

1. Legal authority for the Cross-Connection Control program.
2. Policy establishing the appropriate level of backflow protection at the service connection for the appropriate category of customer.
3. Policies regarding responsibility for installation, inspection, testing, and maintenance of backflow preventers at the service connection.
4. Procedures for assessing new or existing service connections to determine the need for backflow prevention at the service connection.
5. Procedures for record keeping.
6. Procedures for educating the public about cross-connections and backflow prevention.
7. Procedures for investigating and responding to cross-connection and backflow incidents.

This Cross-Connection Control Manual was adopted on June 13, 2018, by Resolution No. 2018-003 of the TOHO Board of Supervisors. Additional information regarding these policies or procedures may be obtained by contacting the TOHO Cross-Connection Control program at (407) 954-4564 for commercial questions or (407) 944-5059 for residential or BackflowCompliance@tohowater.com.

This Manual includes materials and definitions from Recommended Practice for Backflow Prevention and Cross-Connection Control, M14, Fifth Edition, Copyright © 2015/2024, American Water Works Association.

Revised Date: March 2026
Reviewed Date: March 2026
Board Approval Date: April 2026

Preface..... 2

Introduction..... 3

SECTION 1: Purpose and Legal Authority 6

 Purpose: 6

 Legal Authority: 6

SECTION 2: Definitions 6

Definitions for the purpose of this manual: 6

SECTION 3: Responsibility 11

 Responsibility: 11

 Figure 3.1. Typical RPBA Installation 12

 Figure 3.2. Typical PVB Installation 12

 Figure 3.3. Typical DC Installation 13

 Figure 3.4 Typical DuC Installation 13

SECTION 4: Surveys and Inspections 13

 Site Surveys: 13

 Cross-Connection Inspections: 14

SECTION 5: Installation and Maintenance 15

 Installation:..... 15

 New Service Requirements 16

 Residential Specifications..... 16

 Internal Lift Stations and Irrigation Jumpers..... 17

 Backflow Scenarios..... 17

 Alternative Water/Irrigation Sources:..... 17

 Wells 17

 Figure 5.1 Backflow Scenarios..... 18

 Inspection and Testing:..... 20

 Reclaimed Inspections..... 20

SECTION 6: Record Keeping 21

 Record Keeping: 21

SECTION 7: Public and Customer Education 22

 Education:..... 22

SECTION 8: Jumpers and Interconnects 22

Revised Date: March 2026
Reviewed Date: March 2026
Board Approval Date: April 2026

SECTION 9: Construction Hydrant Meters 22

SECTION 10: Fire Protection..... 23

Appendix A..... 24

Backflow Device By Customer Type..... 24

Appendix B 28

Tester’s Code of Conduct..... 28

Revised Date: March 2026
Reviewed Date: March 2026
Board Approval Date: April 2026

SECTION 1: Purpose and Legal Authority

Purpose:

The purpose of TOHO's Cross-Connection Control program is to protect the public water system from contamination and pollution. This manual and the program are designed to inform TOHO's customers (residential and commercial) and contractors of the requirements for backflow protection.

The program promotes the elimination of cross-connections, actual or potential.

The State of Florida requires Community Water System (CWS) purveyors to implement a cross-connection program and manual.

Legal Authority:

TOHO's Cross-Connection program is established through the provisions of the Florida Safe Drinking Water Act (Sections 403.850-403.885, Florida Statutes). Cross connection as defined in Rule 62-550.200 F.A.C. is prohibited. The minimum requirements for Cross-Connection control are also outlined by the State of Florida Department of Environmental Protection (FDEP) under chapters 62-550, 62-555, and 62-610 of the Florida Administrative Code; Chapter 4A-46, Division of State Fire Marshal, Fire Protection Contractors and Systems; Chapter 633, Fire Prevention and Control of the Florida State Statutes (F.S.); and the most current edition of the Florida Building Code.

State law requires that all public water suppliers must protect against backflow by complying with the recommendations in the American Water Works Association (AWWA) M14 manual. In accordance with Part III of Chapter 62-610, F.A.C., water suppliers that have service areas served by reclaimed water are required to maintain a cross-connection control program.

SECTION 2: Definitions

Definitions for the purpose of this manual:

1. Air-Gap Separation
The unobstructed vertical distance through free atmosphere between the lowest effective opening from any pipe or faucet conveying water or waste to a tank, plumbing fixture, receptor, or other assembly and the flood level rim of the receptacle. These vertical, physical separations must be at least twice the effective opening of the water supply outlet, but never less than 1 in. (25mm) above the receiving vessel flood rim.
2. Approved
Accepted by the authority having jurisdiction as meeting an applicable standard, specification, or requirement as suitable for the proposed use.
3. Approved Check Valve
Check valve that is drip-tight in the normal direction of flow when the inlet pressure is at least one pound per square inch (psi) and the outlet pressure is zero. The check valve shall permit no

Revised Date: March 2026
Reviewed Date: March 2026
Board Approval Date: April 2026

leakage in a direction reverse to the normal flow. The closure element (e.g., clapper, poppet, or other design) shall be internally loaded to promote rapid and positive closure.

4. Assembly
A backflow prevention device equipped with approved shut-off valves and testable in-line.
5. Atmospheric Pressure
This pressure is the force exerted on an area by the atmosphere surrounding our planet. The pressure value will change with elevation or thickness of the atmosphere's layer. At sea level, the atmospheric pressure is approximately 14.7psi, while the atmospheric pressure in Denver, Colorado, which is nearly 1mile above sea level, is about 12psi.
6. Auxiliary Water Supply
Any water supply on or available to the premises other than the purveyor's approved public water supply. These auxiliary waters may include water from another purveyor's public potable water supply or any natural source(s), such as a well, lake, spring, river, stream, or harbor, ; or used waters or industrial fluids
7. Backflow
The undesirable reversal of flow of a liquid, gas, or other substance in a piping system.
8. Backflow Preventer
An assembly, device, or method that prevents backflow.
9. Backpressure
Backpressure is downstream pressure that is greater than the potable water supply pressure
10. Backsiphonage
Backsiphonage is backflow caused by negative pressure (i.e., a vacuum or partial vacuum) in a public water system or consumer's potable water system
11. Bypass
Any arrangement of pipes, plumbing, or hoses designed to divert the flow around an installed device through which the flow normally passes.
12. Certified Backflow Prevention Assembly Tester
A person who has demonstrated competence as evidenced by certification that is issued by an approving authority to field test backflow prevention assemblies and recognized by Toho and signed and provided the attached Code of Conduct referenced in Appendix B
13. Contamination
An impairment of a potable water supply by the introduction or admission of any foreign substance that degrades the quality of the water and creates a potential or actual health hazard.

Revised Date: March 2026
Reviewed Date: March 2026
Board Approval Date: April 2026

14. Cross-Connection
A cross-connection is any temporary or permanent connection between a public water system or consumer's potable (i.e., drinking) water system and any source or system containing non-potable water or other substances.
15. Cross-Connection Control (CCC)
A program to eliminate cross-connections or to prevent them from causing a public health hazard.
16. Customer
The owner or operator of a private plumbing and/or water system who receives water from TOHO.
17. Degree of Hazard (DOH)
The assessment or evaluation of a customer's potential for cross-connections, contaminants, or pollutants entering TOHO's public water supply system
18. Device
A device contains the functional components of a backflow assembly, but lacks the shutoff valves and testable components
19. Double Check Detector Backflow Prevention Assembly (DC or DCDA)
A mechanical backflow prevention assembly specifically designed with a line-size-approved double check valve assembly with a bypass containing a specific water meter and an approved double check valve assembly. The meter shall register accurately for only very low rates of flow up to 2 gallons per minute (gpm) and shall show registration for all rates of flow. This assembly shall only be used to protect against a non-health hazard (i.e., a pollutant).
20. Double Check Valve Assembly (DC or DCVA)
A backflow prevention assembly consisting of two internally loaded independently operating check valves, located between two tightly closing resilient-seated shutoff valves with four properly placed resilient-seated test cocks. This assembly shall only be used to protect against a non-health hazard (i.e. a pollutant).
21. Dual Check Backflow Prevention Device (DuC)
A backflow prevention device composed of two internally loaded and independently operating check valves. This device can be used to stop backflow from backpressure and/or backsiphonage and shall only be used for low hazard applications such as residential domestic service. These devices are not testable.
22. Flood Level Rim
That level from which liquid in plumbing fixtures, appliances, or vats could overflow to the floor, when all drain and overflow openings built into the equipment are obstructed.
23. Health Hazard
A cross-connection or potential cross-connection involving any substance that could, if

Revised Date: March 2026
Reviewed Date: March 2026
Board Approval Date: April 2026

introduced into the potable water supply, cause death or illness, or spread disease, or have a high probability of causing such effects.

24. Hydrant Meter
A temporary meter that is typically used for new construction projects where a permanent meter is either not available, not necessary or doesn't meet job requirements. This meter is connected to a fire hydrant and secured in place by Toho staff
25. Inspection
A visual examination of a backflow protection device or assembly materials, workmanship, or portion thereof to verify installation and operational performance of the device or assembly.
26. Inspector
An individual working for or under the authority having jurisdiction (AHJ) and empowered to ensure code compliance.
27. Interconnect
A physical connection between two separate water systems that allows for the transfer or sharing of potable water in emergencies, routine operations, or for mutual aid.
28. Jumper
A temporary meter that is used to establish new water mains. They 'jump' from an existing water main to a new main to conduct pressure tests, obtain FDEP clearance, etc. These are not intended to be connected to a fire hydrant
29. Non-Health Hazard
Any substance that generally would not be a Health Hazard but would constitute a nuisance or be aesthetically objectionable if introduced into the potable water supply.
30. Pollution
The presence of any foreign substance in water that tends to degrade its quality so as to constitute a non-health hazard or impair the usefulness of the water.
31. Potable Water
Water that is safe for human consumption as described by the public health AHJ.
32. Pressure Vacuum Breaker Assembly (PVB)
A mechanical backflow prevention assembly consisting of an independently operating internally loaded check valve, an independently operating spring-loaded air inlet valve located on the discharge side of the check valve, with properly located resilient-seated test cocks and tightly closing resilient-seated shutoff valves attached at each end of the assembly. This assembly is designed to operate under pressure for prolonged periods of time to prevent only backsiphonage. The assembly shall be installed at least twelve inches above the highest outlet. The pressure vacuum breaker may not be subjected to any backpressure.

Revised Date: March 2026
Reviewed Date: March 2026
Board Approval Date: April 2026

33. Reclaimed Water
Water that, as a result of treatment of wastewater, is suitable for a direct beneficial use or a controlled use that would not otherwise occur and is not considered safe for human consumption.
34. Reduced Pressure Principle Backflow Prevention Assembly (RP)
A backflow prevention assembly consisting of two independently acting approved spring-loaded check valves together with a hydraulically operating, mechanically independent, spring-loaded pressure differential relief valve located between the check valves and below the first check valve. These units are located between two tightly closing resilient-seated shutoff valves as an assembly and are equipped with properly located resilient-seated test cocks.
35. Service Connection
The connection between the public water system distribution system main and a user's domestic water system
36. Tohopekaliga Water Authority, TOHO, or Toho Water
An independent special district established and created pursuant to Chapter 189, Florida Statutes, by special act of the Florida Legislature.
37. Water Purveyor
The owner or operator of a public potable water system.

Revised Date: March 2026
Reviewed Date: March 2026
Board Approval Date: April 2026

SECTION 3: Responsibility

Responsibility:

Classification	Initial Installation/Testing	Existing Property with Service Prior to Jan 2018	Ongoing Testing	Maintenance, Repair & Replacement
Commercial	Customer	Customer	Customer	Customer
Residential (Includes Irrigation and Customers with Alternative Water Sources)	Builder	TOHO	TOHO	TOHO

TOHO provides protection at the point of connection to TOHO’s water supply. For above ground residential CCC assemblies, TOHO is responsible for maintaining the backflow assembly up to the discharge of the elbow immediately in the ground (from inflow elbow immediately in the ground). For in-ground residential CCC assemblies and devices, TOHO is responsible for maintaining these devices at the discharge point. If the assembly has been relocated, the property owner will be responsible for the additional piping installed for the purpose of relocating the assembly to a preferential location. TOHO has responsibility for the areas indicated in Figures 3.1 to 3.4 associated with the assembly and the piping if the assembly is located within 18” of the meter.

Dual Check (DuC) devices are considered part of the service assembly and are the responsibility of Toho to maintain, repair and replace.

Testing, repair, and replacement of CCC assemblies for commercial customers are the sole responsibility of the property owner.

Figure 3.1. Typical RPBA Installation

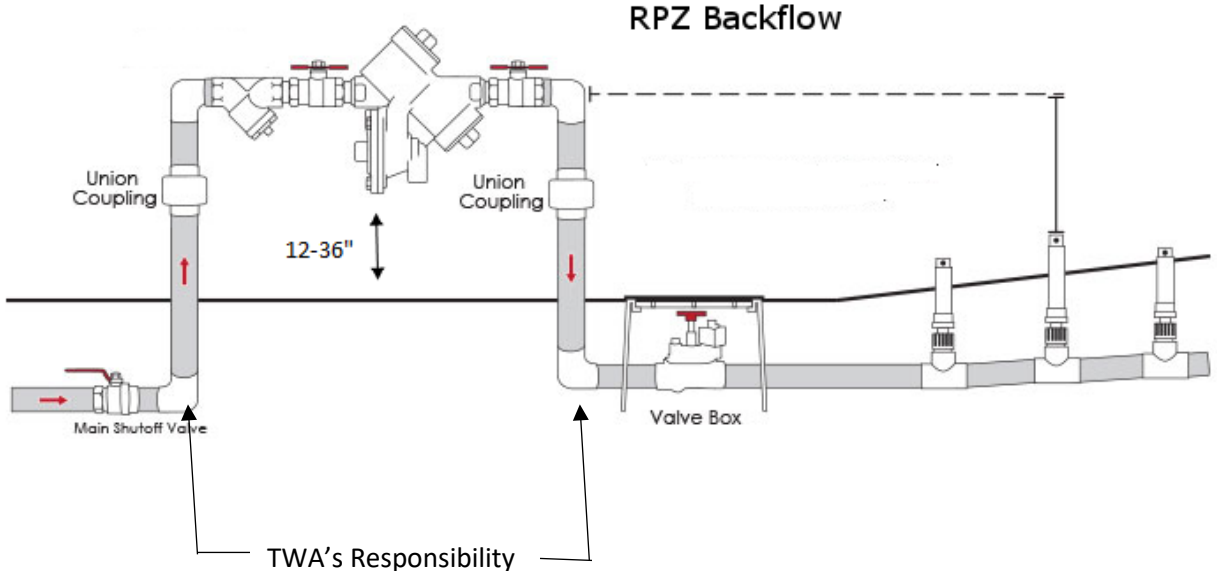
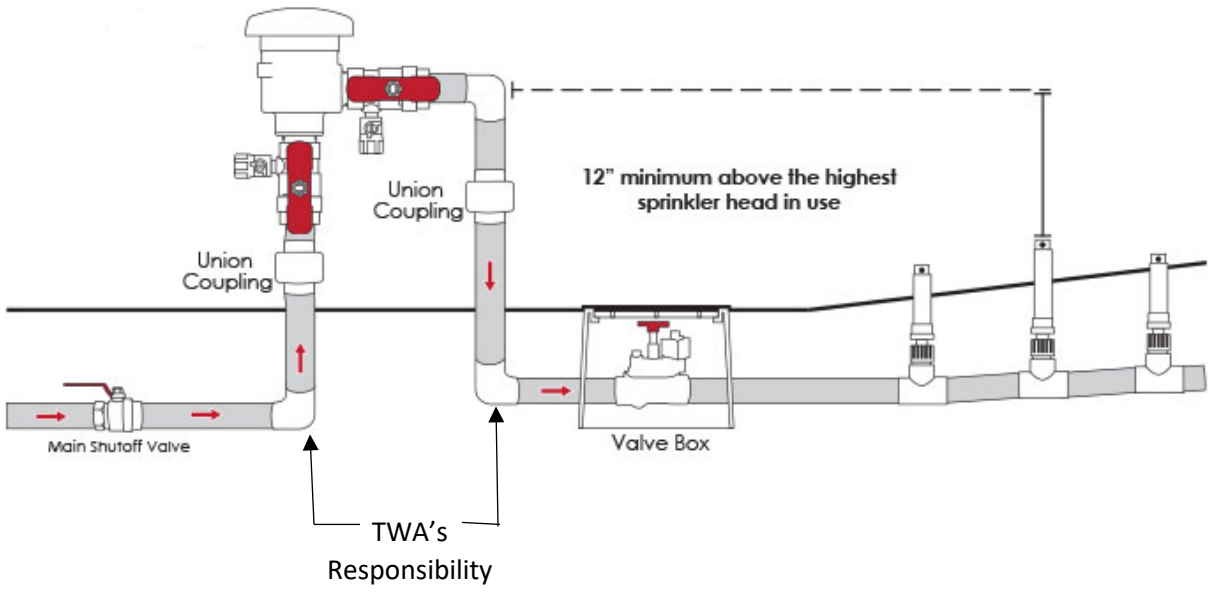

Figure 3.2. Typical PVB Installation



Revised Date: March 2026
Reviewed Date: March 2026
Board Approval Date: April 2026

Figure 3.3. Typical DC Installation

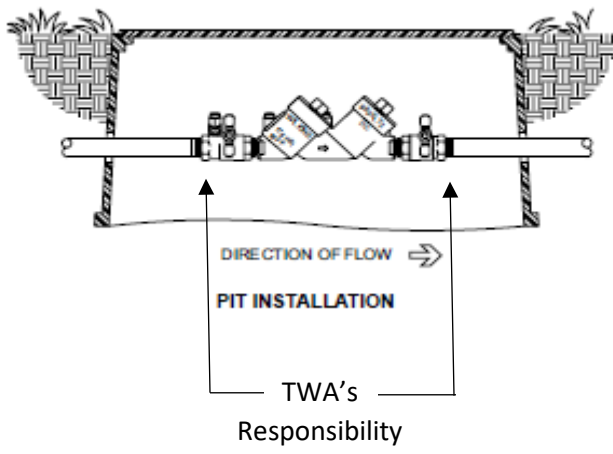
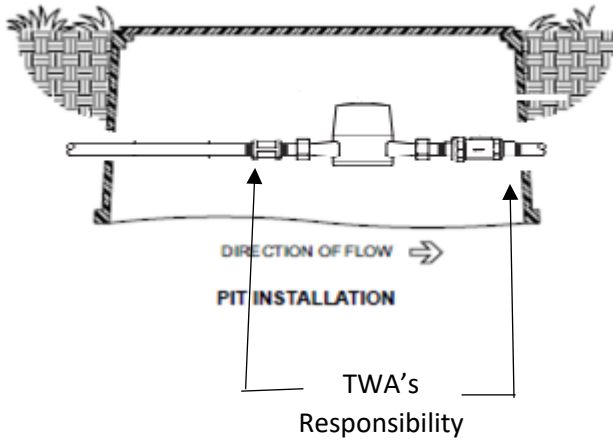

Figure 3.4 Typical DuC Installation



SECTION 4: Surveys and Inspections

Site Surveys:

TOHO will assess a new service location for proper backflow protection based upon the degree of hazard present. This is accomplished via a site survey. Cross-connection surveys are conducted to identify and control cross-connections as part of a multiple barrier approach to protect the drinking water supply. TOHO staff or other certified contractors may provide this service. Customers are

Revised Date: March 2026
Reviewed Date: March 2026
Board Approval Date: April 2026

required to provide access for properly identified TOHO staff or contractors during all reasonable hours to perform the survey.

TOHO may conduct periodic surveys of its existing service areas to determine if any protection requirements have changed, and backflow protection is needed.

Service locations that receive reclaimed water will be inspected at the time of connection and prior to initial service. Once the proper CCC measure has been installed properly, reclaimed service will be initiated.

In most instances, a site survey is performed on the exterior of a service address. However, due to the various natures of commercial and residential setups, consultation with the customer and an internal survey of the facility may be necessary to properly determine the degree of hazard and the appropriate CCC device. A site survey will contain the following minimum information:

- Date
- Inspector's Name
- Meter(s) Manufacturer
- Meter(s) Serial #
- Address
- Customer Contact Information
- Business Name
- Business Type
- Degree of Hazard
- Type of CCC Device(s) Present
- Recommended CCC Device(s)
- Cross-Connection Comments

TOHO may also utilize customer questionnaires to assist the physical surveys and to continue to educate its customers on the meaning and importance of backflow and cross-connection control.

Cross-Connection Inspections:

These inspections are performed to verify that only potable water is entering a customer's facility, and no illicit or prohibited connections are identified. If TOHO discovers a prohibited connection during these inspections, the connection and/or service will be subject to termination immediately. Any restoration cost and/or the cost of returning to the allowed connection type will be the sole responsibility of the customer.

These inspections are performed by turning off the potable domestic/drinking water meter and verifying that the customer has no water volume or pressure inside their facility. In a reclaimed area, the inspector will also terminate the reclaimed meter to verify that none of the above ground hose bibbs have reclaimed water flowing through them. If it's discovered that reclaimed water is present at the hose bibb, the customer will be notified that the connection must be severed within no more than fourteen (14) calendar days.

The customer will have the option:

Revised Date: March 2026
Reviewed Date: March 2026
Board Approval Date: April 2026

- Have TOHO sever the connection at no cost
- The customer may sever the connection themselves or hire a contractor, at no expense to TOHO, to sever the connection.
 - If the customer does it themselves or hires a contractor, they must notify TOHO to perform an additional inspection to verify the connection has been severed and documented.

SECTION 5: Installation and Maintenance

Installation:

All backflow prevention assemblies shall be selected in accordance with the University of Southern California's (USC) Foundation for Cross-Connection Control Approved List of Backflow Prevention Assemblies. All backflow prevention assemblies shall be installed in accordance with the manufacturer's installation instructions, American Water Works Association (AWWA) M14 manual and TOHO specifications.

The Florida Department of Environmental Protection (FDEP) 555-360 Cross-Connection Rule does not allow for any exceptions or exemptions. All existing and future customers in the TOHO service area must meet current FDEP and TOHO cross-connection protection requirements.

All commercial customers are considered high hazard and therefore are required to install RPBA's at all potable water meters.

Current Residential backflow requirements are determined via a degree of hazard survey or by direct knowledge of the property (see Backflow Scenarios).

Pipelines shall be thoroughly flushed to remove foreign material and debris before installing the assembly.

If not already provided, approved shut off valves must be installed at each end of the assembly for testing and servicing purposes (refer to the USC Approved List of Backflow Prevention Assemblies to match the proper shutoff valves with the appropriate backflow device).

The assembly shall be placed in the horizontal position unless otherwise specified by manufacturer's instructions and authorized by TOHO.

The assembly shall always be installed in an accessible location to facilitate testing and servicing. Devices shall be clear of vegetation including landscaping.

Unless otherwise approved by TOHO, the assembly shall always be installed with the lowest point of the assembly, a minimum of 12 inches to no more than 36 inches above the surrounding grade and floodplain for reduced pressure principal assemblies

The Pressure Vacuum Breaker should be installed 12 inches above the highest point of use and any downstream piping supplied from the pressure vacuum breakers.

Revised Date: March 2026
 Reviewed Date: March 2026
 Board Approval Date: April 2026

Double check assemblies may be installed in a separate meter box below grade level.

For commercial services, all piping and fittings shall be of brass construction. For residential services, all piping and fittings shall be of schedule 80 PVC construction.

The assembly shall meet the standards of the Standard Plumbing Code and AWWA Standards.

Service Requirements

Residential-Toho			
Property Type	Connection Type	Hazard	Requirement
New	Potable Meter	None	DuC
New	Potable Meter	Well	DuC/RP*
New	Potable Meter (Irrigation System teed off)	Irrigation System	RP/DC**
New	Potable Meter	Reclaimed	DuC
New	Irrigation Meter	No Irrigation System	Locked Out***
New	Irrigation Meter	Irrigation System	RP/DC**

Commercial	
Connection Type	Requirement
Potable and Irrigation Service Connection	RP

* If well is abandoned/capped: DuC; If well connected to separate irrigation system: RP

** If irrigation is established <05/05/2014: DC; If >05/05/2014: RP

*** Lock out via hard lock and add comment to CIS

Residential Specifications

For new assembly installations and replacements, ¾" - 2" TOHO will allow:

- RP
 - Wilkins lead free Model 975XL2
 - Wilkins lead free Model 975XL3

- DC
 - Wilkins lead free Model 950XLT2
 - Wilkins lead free Model 950XL3

- PVB (Replacements Only)
 - Watts Model LF800M4

- DuC
 - Ford HHS
 - Watts LF7R
 - Wilkins 700XL

Revised Date: March 2026
 Reviewed Date: March 2026
 Board Approval Date: April 2026

Internal Lift Stations and Irrigation Jumpers

For new assembly installations and replacements, ¾" - 2" TOHO will allow:

- RP
 - Wilkins lead free Model 975XL2
 - Wilkins lead free Model 975XL3

For new assembly installations and replacements, 3" - 10" TOHO will allow:

- RP
 - Wilkins 375

Backflow Scenarios

The diagram in Figure 5.1 is provided to give guidance as to the appropriate level of protection for most scenarios that exist in our service area. This may not represent every scenario encountered in the field. Any exceptions will be taken by the Cross-Connection Control Program.

Dual checks (DuC) will be installed on all potable connections where reclaim irrigation service is present. These will be replaced every 7-10 years.

If the residential potable irrigation system was established prior to 05/05/2014, an in-ground double check assembly may be installed. If the residential potable irrigation system was established after 05/05/2014, an above ground RP assembly must be installed.

Covers or other aesthetic screening are the responsibility of the customer / property owner.

Residential customers may have a private plumber relocate the RP assembly away from the associated meter. This will be at the customer's expense, and they will assume responsibility for the additional footprint of pipe. Toho Water Authority will continue to provide ongoing maintenance of the assembly.

Alternative Water/Irrigation Sources:

An alternative source of water may be utilized for irrigation purposes, provided the following criteria are met:

- No reclaim service is available
- The alternative source being utilized is recognized and approved by TOHO (lake, pond, etc.)

Wells

A well may not be allowed to be interconnected with TOHO service at any time. If a well is connected to a separate irrigation system on-site, an RP will be installed on the TOHO service at the meter. If the well is not connected to an irrigation system, it must be abandoned/capped and inspected by TOHO staff. A DuC will be installed on the TOHO service at the meter.

Revised Date: March 2026
Reviewed Date: March 2026
Board Approval Date: April 2026

Figure 5.1 Backflow Scenarios

Backflow Scenarios

Scenario #1: Dedicated Domestic Meter (For Drinking Water Only)

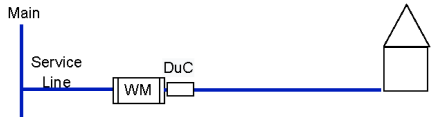

Scenario #2a: Potable With well/aux H2O teed off of a potable/domestic meter - Disconnected

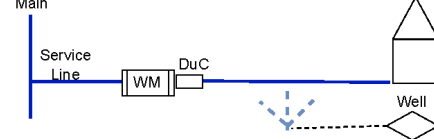

Scenario #2b: Potable With well/aux H2O teed off of a potable/domestic meter - Connected

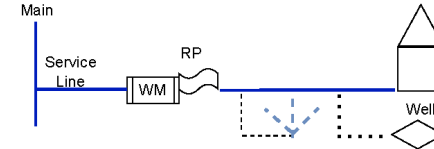

Scenario #3A: Dedicated Potable Irrigation Meter to an irrigation system (After 05/05/2014)

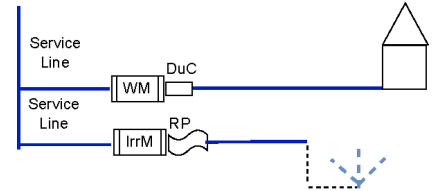

Scenario #3B: Dedicated Potable Irrigation Meter to an irrigation system (Prior to 05/05/2014)

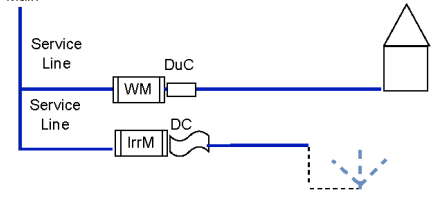

Scenario #4A: Dedicated Reclaimed Irrigation Meter (Jumprec)

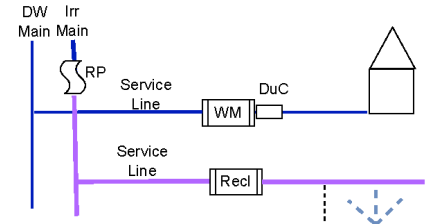

Scenario #4B: Dedicated Reclaimed Irrigation Meter (Real Reclaimed)

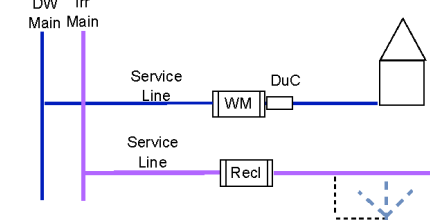

Scenario #5: Private Reclaimed Irrigation Meter (Bellalago, Sollvita) Keep RP on Domestic until dies-Replace with DuC

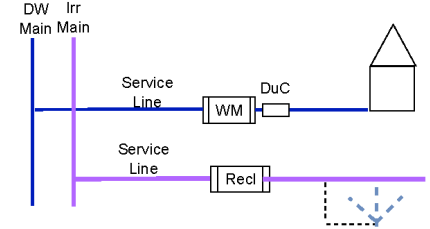

Scenario #6: Commercial Dedicated Potable Irrigation Meter-Same Service Line

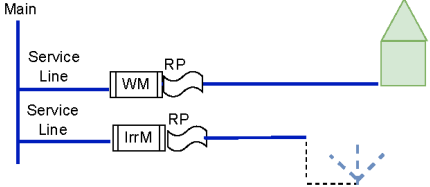

Revised Date: March 2026
 Reviewed Date: March 2026
 Board Approval Date: April 2026

d)

Scenario #7A: Commercial Dedicated Potable Irrigation System- Separate Service Line

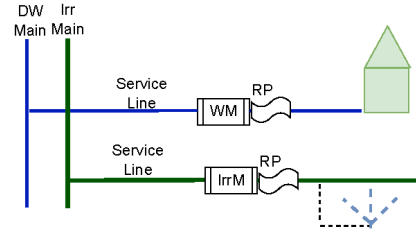

Scenario #7B: Commercial Bulk Delivery Potable Irrigation System

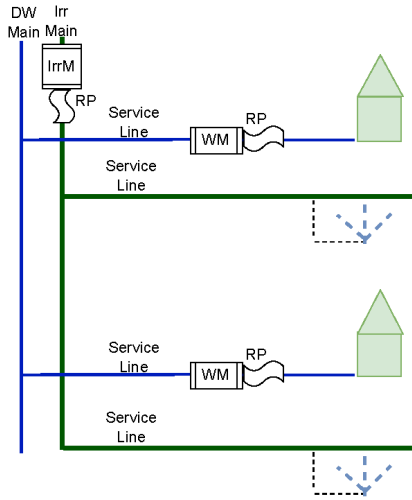

Scenario #8: Multiple residential neighborhoods fed by one master RP

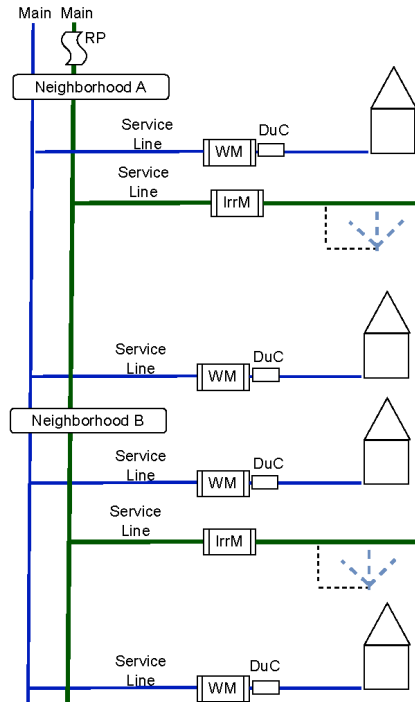

Legend

- DW Main: Drinking Water Main
- Irr Main: Irrigation Water Main
- WM: Water Meter
- IrrM: Irrigation Meter
- DuC: Dual Check Valve
- DC: Double Check Valve
- CV: Single Check Valve
- RP: Reduced Pressure Backflow Prevention Assembly

Backflow Scenarios:

This Backflow Scenario Diagram is representative of most of the Backflow situations encountered within Toho's service area. However, there may/will be unique scenarios that are not addressed by these diagrams. In these situations, please reach out to the Cross-Connection Control (Backflow) Program at BackflowCompliance@tohowater.com or (407) 944-5059 for assistance

Revised Date: March 2026
 Reviewed Date: March 2026
 Board Approval Date: April 2026

Inspection and Testing:

Residential Testing

All residential backflow assemblies must be tested at the time of initial installation and every 2 years thereafter and the results recorded with TOHO. Backflow assemblies must be tested after repair or replacement. TOHO is responsible for the testing, maintenance, and repair or replacement of these testable assemblies. DuC's and T-10 combo meters are changed as needed or every 10 years in reclaim irrigation service areas.

TOHO Operational Facility Testing

TOHO or their subcontractors will test all TOHO owned lift stations, admin buildings, water and wastewater treatment plants, irrigation jumpers and any other associated TOHO operations-based backflow assemblies on an annual basis.

Commercial Testing

All commercial backflow assemblies must be tested at the time of initial installation and every year thereafter and the results recorded with TOHO. Backflow assemblies must be tested after repair or replacement. The property owner is responsible for the testing, maintenance, and repair or replacement of these assemblies. Test results must be reported to TOHO. A Toho approved inspection tag containing the test date (mm/dd/yyyy) and passing status must be placed on the assembly when testing is complete.

TOHO shall have the right to access the premises at any reasonable time to conduct inspections, testing, repair, and replacement of applicable backflow assemblies.

All backflow assembly testers must be certified by a TOHO approved organization based in the State of Florida. Testers must register with TOHO for their results to be accepted. At any time, TOHO may ask an approved tester to perform bench tests to demonstrate proficiency of their testing skills. All of the testers' equipment current certification/calibration data sheets must be registered with TOHO.

If a backflow assembly has not been tested by a certified tester and the results received and acknowledged by TOHO, service may be discontinued.

If firelines are not in compliance with annual testing requirements, TOHO may discontinue service for irrigation or domestic services to gain compliance. TOHO will not shut down fire services unless a licensed fire contractor is present and is the lead on the job. It is the responsibility of the licensed fire contractor to notify the appropriate authorities of the activities being performed and the expected time lapse in service.

If a cross-connection is identified, a TOHO authorized representative may deny or immediately discontinue service until the service location becomes in compliance with this manual and 555-360. The cost of the reconnection and efforts to remedy the cross-connection will be at the customer's expense.

Reclaimed Inspections

Inspections will be performed at the time of initial connection and periodically thereafter to identify and eliminate any possible cross-connections. In reclaimed systems, the dual check valves are to be

Revised Date: March 2026
Reviewed Date: March 2026
Board Approval Date: April 2026

replaced at least every 7 –10 years. Upon a potable jumpered system being switched to reclaimed, cross-connection inspections will be made at each affected address ahead of the system being charged with reclaimed water.

TOHO maintains several ‘jumpered’ reclaimed irrigation systems. Jumpered systems are irrigation systems that are eventually intended for ‘true reclaimed’ service but currently do not have adequate volume from the reclaimed source and are thusly fed from potable water.

“Reclaimed water,” except as specifically provided in chapter 62-610, F.A.C., means water that has received at least secondary treatment and basic disinfection and is reused after flowing out of a domestic wastewater treatment facility.

For reclaimed services, residential dual check valves shall be installed at the domestic meter.

Above ground hose bibbs are not allowed to be connected to reclaim service. Only below ground irrigation systems are permitted to be connected to reclaim services. If these above ground connections are discovered by TOHO or its contractors, TOHO will notify the customer that the connection must be severed. This may be done by the customer, at no cost to Toho, or at customer’s request TOHO will provide the service.

SECTION 6: Record Keeping

Record Keeping:

TOHO shall keep all records and documentation related to backflow prevention for a minimum of 10 years in accordance with FDEP rules 62-555.360 and 62-550.720(3). All electronic data will be archived on a periodic basis to allow for database optimization.

All backflow assembly test reports must be submitted electronically to the TOHO online portal.

An inventory of all cross-connection related equipment will be maintained by TOHO in an electronic database format. This will include:

- Backflow Serial Number
- Backflow Manufacturer and Model Number
- Physical Address of the Backflow Assembly
- Associated Meter Number
- Installation Date
- All Calibration/Test Results
- All Repairs and Maintenance
- Removal/Replacement Date

Revised Date: March 2026
Reviewed Date: March 2026
Board Approval Date: April 2026

SECTION 7: Public and Customer Education

Education:

TOHO may utilize the following and other methods to continue to educate customers and the general public about cross-connections:

- Questionnaires
- Publish information regarding the cross-connection control program in the annual consumer confidence report
- Publish a brochure available on TOHO's homepage or a physical version for handing out at physical events
- Billing inserts related to cross-connection control
- Advertising
- Door Hangers

SECTION 8: Jumpers and Interconnects

All TOHO owned jumpers and interconnects will be tested annually by TOHO staff or their subcontractors. TOHO's GIS repository is the source of all jumpers and interconnects. TOHO will maintain the records of test results, maintenance and replacement of assemblies and any associated assembly detail information in the cross-connection program management software and TOHO approved record management software.

Any new or removed jumper assemblies must follow the TOHO Jumper Protocol SOP.

If a new interconnect between TOHO and another utility is established, backflow protection is not required provided that the other CWS is of the same type as defined in 555-360. TOHO may require backflow protection as lined out in the inter-agency agreement as part of the interconnect.

SECTION 9: Construction Hydrant Meters

The temporary construction hydrant meter program is maintained by TOHO cross-connection staff. All requests for a hydrant meter need to be made via the hydrant meter portal on TOHO's public facing homepage. Move requests, final pickup and monthly required read submittals can also be made via the hydrant meter portal.

All hydrant meters will be delivered, locked, and secured by TOHO staff unless otherwise approved by the cross-connection program. If the hydrant meter is issued for longer than a 1 year period, the meter may be required to be brought back to the TOHO yard for annual inspection, or it may be serviced in place.

If a hydrant meter is found to have been tampered with or the locking mechanism removed, the entity who has been issued the meter will be subject to fines, commensurate with TOHO's fee schedule, in an amount up to and even above the full deposit amount.

Revised Date: March 2026
Reviewed Date: March 2026
Board Approval Date: April 2026

Once a hydrant meter has been issued, it is the responsibility of the contractor. IF the meter is lost or stolen, the contractor must notify the local authorities and submit the theft report to TOHO. The contractor may be subject to forfeiture of their deposit amount to cover the replacement cost.

Temporary jumper meters may only be used for their intended purpose. They may not be modified to be connected to a fire hydrant or other source of water. If a contractor wishes to move a jumper meter from one job to another, they must notify cross-connection staff. If the jumper meter is discovered on a site other than the one issued, the meter will be subject to confiscation and fees commensurate with TOHO's fee schedule will be applied.

The inlet side of the jumper shall not be connected to the reclaim main and any connection from potable to reclaim must include an additional contractor provided 2" RP after the jumper assembly setup.

Any confiscated meters that have been altered or require TOHO staff time to restore the original condition may result in fees commensurate with TOHO's fee schedule.

SECTION 10: Fire Protection

Fire suppression systems must utilize a double check with a detector assembly, matched to the pipe diameter of the service. If chemical injection is utilized immediately downstream in the fire suppression system, a reduced pressure backflow with a detector assembly must be utilized.

TOHO will not terminate fire service to a customer without a licensed fire contractor present. The irrigation and domestic services can be terminated to enforce fireline backflow compliance.

For residential fire suppression systems, the homeowner/business owner will be responsible for the annual testing and maintenance of the residential fire suppression system, including the annual backflow testing. The customer will also assume responsibility for the maintenance, testing, replacement, etc. of any additional backflow assemblies on property.

The customer's service must have a curbstop in a meter box and identified via tag or other identifying feature that a fireline/fire sprinkler system is attached to the service.

Revised Date: March 2026
Reviewed Date: March 2026
Board Approval Date: April 2026

Appendix A

Backflow Device By Customer Type

62-555.360 Cross-Connection Control for Public Water Systems.

Category of Customer	Minimum Backflow Protection ¹ to Be Provided at or for the Service Connection from the CWS to the Customer
Beverage processing plant, including any brewery	DC if the plant presents a low hazard ² ; or RP if the plant presents a high hazard ²
Cannery, packing house, rendering plant, or any facility where fruit, vegetable, or animal matter is processed, excluding any premises where there is only restaurant or food service facility	RP
Car wash	RP
Chemical plant or facility using water in the manufacturing, processing, compounding, or treatment of chemicals, including any facility where a chemical that does not meet the requirements in paragraph 62-555.320(3)(a), F.A.C., is used as an additive to the water	RP
Dairy, creamery, ice cream plant, cold-storage plant, or ice manufacturing plant	RP ³
Dye plant	RP
Film laboratory or processing facility or film manufacturing plant, excluding any small, noncommercial darkroom facility	RP
Hospital; medical research center; sanitarium; autopsy facility; medical, dental, or veterinary clinic where surgery is performed; or plasma center	RP
Laboratory, excluding any laboratory at an elementary, middle, or high school	RP
Laundry (commercial), excluding any self-service laundry or Laundromat	RP
Marine repair facility, marine cargo handling facility, or boat moorage	RP
Metal manufacturing, cleaning, processing, or fabricating facility using water in any of its operations or processes, including any aircraft or automotive manufacturing plant	DC if the facility presents a low hazard ² ; or RP if the facility presents a high hazard ²
Mortuary	RP
Premises where oil or gas is produced, developed, processed, blended, stored, refined, or transmitted in a pipeline or where oil or gas tanks are repaired or tested, excluding any premises where there is only a fuel dispensing facility	RP
Premises where there is an auxiliary or reclaimed water system ^{4,5}	A. At or for a residential service connection ⁶ : DuC7 B. At or for a non-residential service connection ⁶ : DC if the auxiliary or reclaimed water is a low hazard ^{8,9} ; or RP if the auxiliary or reclaimed water is a high hazard ^{8,9}
Premises where there is a cooling tower	RP

Revised Date: March 2026
Reviewed Date: March 2026
Board Approval Date: April 2026

Category of Customer	Minimum Backflow Protection ¹ to Be Provided at or for the Service Connection from the CWS to the Customer
Premises where there is an irrigation system that is using potable water and that... I. Is connected directly to the CWS's distribution system via a dedicated irrigation service connection II. Is connected internally to the customer's plumbing system	I. At or for a residential or non-residential dedicated irrigation service connection ⁶ : PVB if backpressure cannot develop in the downstream piping ¹⁰ ; or RP if backpressure could develop in the downstream piping ¹⁰ II. None ¹¹
Premises where there is a wet-pipe sprinkler, or wet standpipe, fire protection system that is using potable water and that... I. Is connected directly to the CWS's distribution system via a dedicated fire service connection ¹² II. Is connected internally to the customer's plumbing system	I.A. At or for a residential dedicated fire service connection ⁶ : DuC if the fire protection system contains no chemical additives and is not connected to an auxiliary water system ⁴ ; or RP or RPDA if the fire protection system contains chemical additives or is connected to an auxiliary water system ^{4,13} I.B. At or for a non-residential dedicated fire service connection ⁶ : DC or DCDA if the fire protection system contains no chemical additives and is not connected to an auxiliary water system ⁴ ; or RP or RPDA if the fire protection system contains chemical additives or is connected to an auxiliary water system ^{4,13} II. None ¹¹
Radioactive material processing or handling facility or nuclear reactor	RP
Paper products plant using a wet process	RP
Plating facility, including any aircraft or automotive manufacturing plant	RP
Restricted-access facility	RP
Steam boiler plant	RP

Revised Date: March 2026
Reviewed Date: March 2026
Board Approval Date: April 2026

Category of Customer	Minimum Backflow Protection ¹ to Be Provided at or for the Service Connection from the CWS to the Customer
Tall building – i.e., a building with five or more floors at or above ground level	DC if the customer has no potable water distribution lines connected to the suction side of a booster pump; or RP if the customer has one or more potable water distribution lines connected to the suction side of a booster pump
Wastewater treatment plant or wastewater pumping station	RP
Customer supplied with potable water via a temporary or permanent service connection from a CWS fire hydrant	Varies ¹⁴

¹ Means of backflow protection, listed in an increasing level of protection, include the following: a dual check device (DuC); a double check valve assembly (DC) or double check detector assembly (DCDA); a pressure vacuum breaker assembly (PVB); a reduced-pressure principle assembly (RP) or reduced-pressure principle detector assembly (RPDA); and an air gap. A PVB may not be used if backpressure could develop in the downstream piping.

² The CWS shall determine the degree of hazard. “Low hazard” or “non-health hazard” and “high hazard” or “health hazard” are defined in *AWWA Manual M14* as incorporated in paragraph 62-555.360(1)(a), F.A.C., and subsection 62-555.360(2), F.A.C.

³ A DC may be provided if it was installed before 5-5-14; and if such a DC is replaced on or after 5-5-14, it may be replaced with another DC.

⁴ For the purpose of this table, “auxiliary water system” means a pressurized system of piping and appurtenances using auxiliary water, which is water other than the potable water being supplied by the CWS and which includes water from any natural source such as a well, pond, lake, spring, stream, river, etc., includes reclaimed water, and includes other used water or industrial fluids described in *AWWA Manual M14* as incorporated in paragraph 62-555.360(1)(a), F.A.C., and subsection 62-555.360(2), F.A.C.; however, “auxiliary water system” specifically excludes any water recirculation or treatment system for a swimming pool, hot tub, or spa. (Note that reclaimed water is a specific type of auxiliary water and a reclaimed water system is a specific type of auxiliary water system.)

⁵ The Department shall allow an exception to the requirement for backflow protection at or for a residential or non-residential service connection from a CWS to premises where there is an auxiliary or reclaimed water system if all of the following conditions are met:

- The CWS is distributing water only to land owned by the owner of the CWS.
- The owner of the CWS is also the owner of the entire auxiliary or reclaimed water system up to the points of auxiliary or reclaimed water use.
- The CWS conducts at least biennial inspections of the CWS and the entire auxiliary or reclaimed water system to detect and eliminate any cross-connections between the two systems.

⁶ For the purpose of this table, “residential service connection” means any service connection, including any dedicated irrigation or fire service connection, that is two inches or less in diameter and that supplies water to a building, or premises, containing only dwelling units; and “non-residential service connection” means any other service connection.

⁷ A DuC may be provided only if there is no known cross-connection between the plumbing system and the auxiliary or reclaimed water system on the customer’s premises. Upon discovery of any cross-connection between

Revised Date: March 2026
Reviewed Date: March 2026
Board Approval Date: April 2026

the plumbing system and any reclaimed water system on the customer's premises, the CWS shall ensure that the cross-connection is eliminated. Upon discovery of any cross-connection between the plumbing system and any auxiliary water system other than a reclaimed water system on the customer's premises, the CWS shall ensure that the cross-connection is eliminated or shall ensure that the backflow protection provided at or for the service connection is equal to that required at or for a non-residential service connection.

⁸ Reclaimed water regulated under Part III of Chapter 62-610, F.A.C., is a low hazard unless it is stored with surface water in a pond that is part of a stormwater management system, in which case it is a high hazard; well water is a low hazard unless determined otherwise by the CWS; industrial fluids and used water other than reclaimed water are high hazards unless determined otherwise by the CWS; reclaimed water not regulated under Part III of Chapter 62-610, F.A.C., and surface water are high hazards.

⁹ Upon discovery of any cross-connection between the plumbing system and any reclaimed water system on the customer's premises, the CWS shall ensure that the cross-connection is eliminated.

¹⁰ A DC may be provided if both of the following conditions are met:

- The dedicated irrigation service connection initially was constructed before 5-5-14.
- No chemicals are fed into the irrigation system.

¹¹ The CWS may rely on the internal backflow protection required under the *Florida Building Code* or the predecessor State plumbing code. The CWS may, but is not required to, ensure that such internal backflow protection is inspected/tested and maintained the same as backflow protection provided at or for service connections from the CWS.

¹² The Department shall allow an exception to the requirement for backflow protection at or for a residential or non-residential dedicated fire service connection from a CWS to a wet-pipe sprinkler, or wet standpipe, fire protection system if both of the following conditions are met:

- The fire protection system was installed and last altered before 5-5-14.
- The fire protection system contains no chemical additives and is not connected to an auxiliary water system as defined in Footnote 4.

¹³ Upon discovery of any cross-connection between the fire protection system and any reclaimed water system on the customer's premises, the CWS shall ensure that the cross-connection is eliminated.

¹⁴ The CWS shall ensure that backflow protection commensurate with the degree of hazard is provided at or for the service connection from its fire hydrant.

Rulemaking Authority 403.086(8), 403.853(3), 403.861(9) FS. Law Implemented 403.086(8), 403.852(12), 403.853(1), 403.855(3), 403.861(17) FS. History—New 11-19-87, Formerly 17-22.660, Amended 1-18-89, 1-3-91, 1-1-93, Formerly 17-555.360, Amended 8-28-03, 5-5-14.

Revised Date: March 2026
Reviewed Date: March 2026
Board Approval Date: April 2026

Appendix B
Tester's Code of Conduct

Backflow Tester's Code of Conduct

The purpose and intent of this document is to establish the professional, ethical, and technical standards expected of certified testers. This document synthesizes the best practices and regulatory requirements from Toho Water Authority (TOHO) and industry guidelines:

Professionalism and Integrity

- Maintain a current, valid backflow tester certification and up-to-date gauge calibration certificate as required by TOHO
- Perform all tests personally; do not sign reports for tests not conducted by you
- Refrain from knowingly falsifying or misrepresenting any test results, records, or reports
- Do not make unnecessary repairs or fail a device simply to generate additional business
- Treat customers, property owners, and water purveyor staff with respect and professionalism at all times

Compliance and Reporting

- Follow all proper test procedures as established by approved training and regulatory guidelines
- Use only calibrated and authorized test equipment; do not use expired or non-calibrated devices
- Submit complete, legible, and accurate test reports to the water purveyor within 10 days of the test, regardless of test outcome
- Ensure all data (make, model, size, serial number, meter number, pass/fail status, etc.) is confirmed and accurately recorded at the time of testing and reporting
- When replacing an assembly, the previous serial number should be documented on the associated test report

Ethics and Responsibility

- Clearly document any failures, repairs, or unusual conditions in the test report (e.g., leaks, missing devices, evidence of tampering)
- Clearly document/record if a new or replacement assembly is installed, providing all required details
- Take reasonable precautions to prevent backflow during testing and repair activities

Revised Date: March 2026
Reviewed Date: March 2026
Board Approval Date: April 2026

Accountability

- Understand that your signature on a test report attests to the accuracy and truthfulness of all information provided
- Be aware that repeated complaints, noncompliance, or violations of this code may result in removal from approved tester lists or other disciplinary action by the water authority
- At any time, TOHO may ask an approved tester to perform bench tests to demonstrate proficiency of their testing skills

Acknowledgement

I hereby certify that I have read, fully understand and agree to comply with these conditions. My failure to comply with these standards may lead to my removal from the TOHO Approved Tester’s List and a refusal of future acceptance of submitted testing documents.

Tester’s Signature

Date

Tester’s Printed Name

Business Name

Business Phone Number

TOHO Signature

Date Of Approval

TOHO Printed Name

Revised Date: March 2026
Reviewed Date: March 2026
Board Approval Date: April 2026